



BUILT FOR LIFE.

*Engineered for Performance.*

# Window Types

## HORIZONTAL SLIDER

- ▶ Offset Sightlines offer more viewing area
- ▶ Sliders available as: XO, OX, XOX  
X=Vent Panel (Operable) O=Fixed Panel (Stationary), viewed from the Outside.
- ▶ Dual adjustable Delrin (Nylon) Rollers with a vinyl track.
- ▶ Cam lock and keeper or optional Auto lock (locks automatically when window is closed)
- ▶ Reinforced meeting rails for added structural support

## SINGLE HUNG

- ▶ Utilizing reliable hardware, our Heritage Series Single Hung window operates smoothly
- ▶ Reliable, concealed block and tackle sash balancers for easy of operation
- ▶ Auto lock (Locks Automatically) or optional Self aligning metal Pro latch.

## FIXED WINDOW

- ▶ Fixed windows are used to create dramatic architectural appeal. A number of creative combinations can be achieved using geometric shapes, arch tops, round tops, half circles and full circle designs.

## CASEMENT AND AWNING WINDOWS

- ▶ Concealed folding handle and low profile hardware
- ▶ Narrow step-down profile frame.
- ▶ Exterior Glazed.

## FRAME SPECIFICATIONS

- ▶ 2 3/4" window (5 1/2" patio door slider) frame depth.
- ▶ Offset sight lines give more glass and a greater viewing area.
- ▶ 3/4" Insulated glass with optional 5/8" flat or 1" sculpted grids.

## FRAME STYLES

- ▶ New construction frame styles are available with 1" or 1 3/8" nail-fin setback, and double stucco key.
- ▶ Choose Retro-fin, or our new, stylish Sig-Fin for replacement installations.

## FRAME COLORS

- ▶ Solid all White or Almond (Tan).
- ▶ Optional two-tone Bronze Supercap exterior (white interior) or Silver Supercap white interior.
- ▶ Other colors available - painted exterior

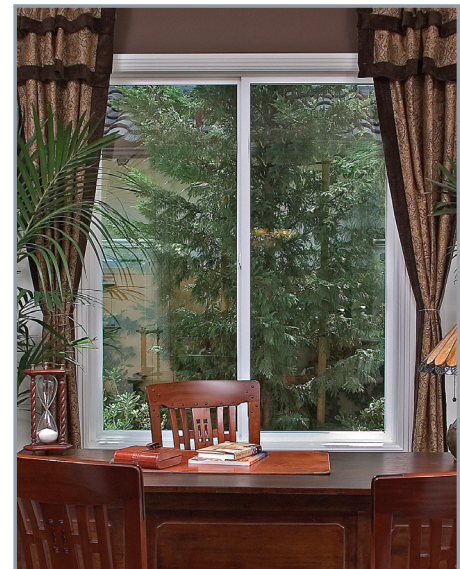

# Glass Packages



**LoE-366™** is a clear coating that blocks even more solar gain, reflects heat, and lets the light stream in. It even outperforms the tinted glass often used in warm climates.



**LoE-340™** delivers exceptionally high UV blocking. This greatly reduces fading on furniture, carpet, drapes, and everything inside the home. s

**CARDINAL**   
Glass Industries

*A window system designed for the Western US marketplace. Ask about Sound reduction glass options.*

# Color Coatings & Hardware Options

## SUPERCAP Exterior colors are 10X harder than paint

Supercap colored doors come with black exterior handles and white or almond interior. Almond and white doors come with matching exterior and three optional interior handle finishes.

Additional color options available in paint.

## 25 Years of Proven Performance:

*SuperCap™ Color Technology That Lasts.*



FRENCH RAIL STYLE PATIO DOOR

### Supercap



BLACK

BRONZE

METALLIC SILVER

### Rollers



BRASS

STAINLESS STEEL

### Interior



ALMOND

WHITE

### Exterior



# Vinyl Window Options

## Lock

Unique, contemporary style interior windowhandle with no exposed screws, ergonomic pull, detent feature and reliable time-tested locking mechanism. Available in white and almond.



## Grid Options

5/8" Flat grids are the standard grid option. For a more traditional look we suggest upgrading to 1" sculpted grids. For even greater detail step up to the beauty of Americana "SDL" (simulated divided lite.) Americana SDL combines the 1" interior sculpted grid with our detailed exterior grid, for a truly authentic wood window look. Lindsay Windows grids are available in standard or custom patterns and colors.



FLAT 5/8" GRID

SCULPTED 1" GRID



CASEMENT WINDOWS

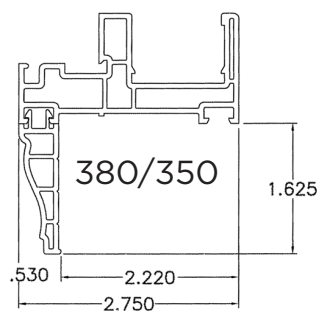

SIGNATURE FIN

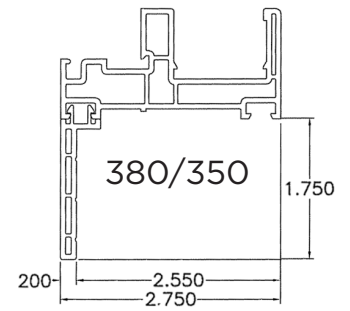

RETRO FIN

# HERITAGE SERIES

TESTED.  
PROVEN.  
SECURE.

*Rigorously Tested for  
Air, Water, and Forced Entry.*



Contact your local dealer or  
Lindsay Windows  
for more information.

## CALIFORNIA

(760) 240-4837

13510 Central Rd

Apple Valley, CA 92308

Other Manufacturing Facilities

MINNESOTA  
MISSOURI  
GEORGIA  
ILLINOIS  
WASHINGTON  
CALIFORNIA  
TEXAS

[www.LindsayWindows.com](http://www.LindsayWindows.com)

## A TRADITION OF QUALITY SINCE 1947

Lindsay Windows began over 75 years ago as a privately held, family-owned company, which it still is today. Our mission has always been to manufacture the highest quality products using materials with advanced manufacturing equipment and procedures.

Our products carry extensive industry certifications and are distributed through a network of qualified dealers. All of our products exceed the current standards for ENERGY STAR compliance and have some of the best ratings in the industry.

Our modern production facilities in Minnesota, Missouri, Illinois, Georgia, Washington and California manufacture vinyl products for energy specific geographical window and door markets. We value our employees and consider every employee a salesperson for our company. It is a privilege to provide you with the finest products that are the best value in the market, with the best energy performance and warranty. Our best testimonies come from our thousands of satisfied customers. **We want you to be one of them.**

Our prices reflect our commitment to craftsmanship, advanced materials and superior performance. We are proudly the third owners of Lindsay Windows for the last 30 plus years.

**Thank You  
Lindsay Team**

Lindsay Dealer



### ENERGY STAR 7.0 (EFFECTIVE OCTOBER 2023)

Our insulating glass offers an optimal energy equilibrium, incorporating effective solar heat management, enhanced visibility, and fade protection. Equipped with gas-filled chambers and Low-E coatings, our windows ensure elevated year-round comfort and exceptional energy efficiency.

